



**HAVERFORD**

**WALKS &  
BIKES**



# 2024 Bike to School Striping/Trails Grows Ridership

Fall 2024 saw explosive growth in Bike/Scooter ridership to  
Haverford Township Middle and High Schools

Peter S. Puglionesi, Friends of Haverford Trails (FHT)

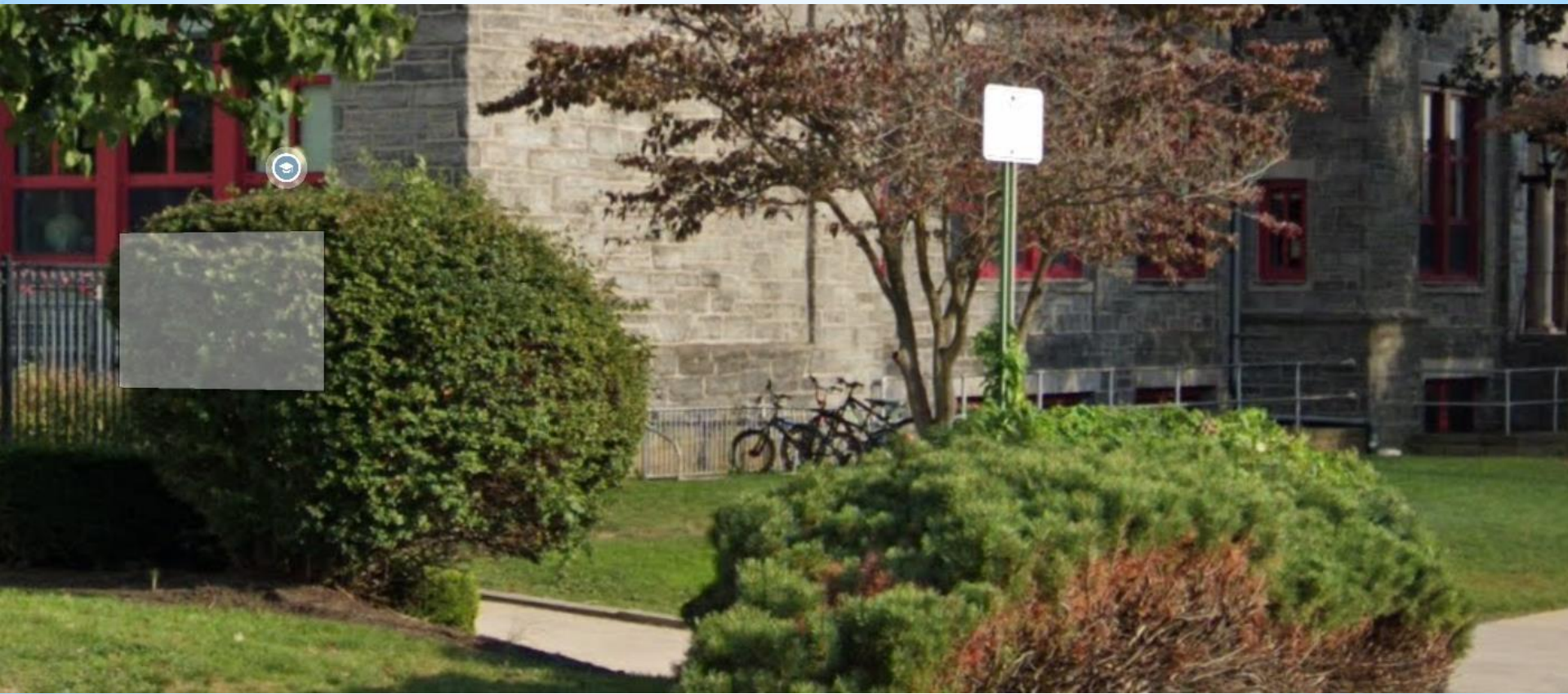

**Oct. 2018: Middle School - a few bikes parked**

**2019:  
New “Bike Lanes”  
(Buffer Stripes) on  
Most of Darby Rd.**



2024:  
New Bike Lanes on  
Brookline Blvd.

Brookline Blvd



© 2024 Google



# New Trail & Bridge



**HAVERFORD**

**WALKS &  
BIKES**

**2024:  
Pennsy Trail  
extension  
with new  
bridge over  
Manoa Rd.**



**Friends of  
Haverford Trails**



**Oct. 2024: Middle School - bikes everywhere!**



**Oct. 2024: Middle School - a hundred or more!**

**Oct. 2024: High School -  
bikes concentrated in  
one area with racks**







**Oct. 2024: High School - few places to latch on**



# Coming Soon



## HAVERFORD

### WALKS & BIKES

FHT / HTCC  
donating 60  
"U" style  
racks with  
capacity for  
120 bikes  
for multiple  
locations

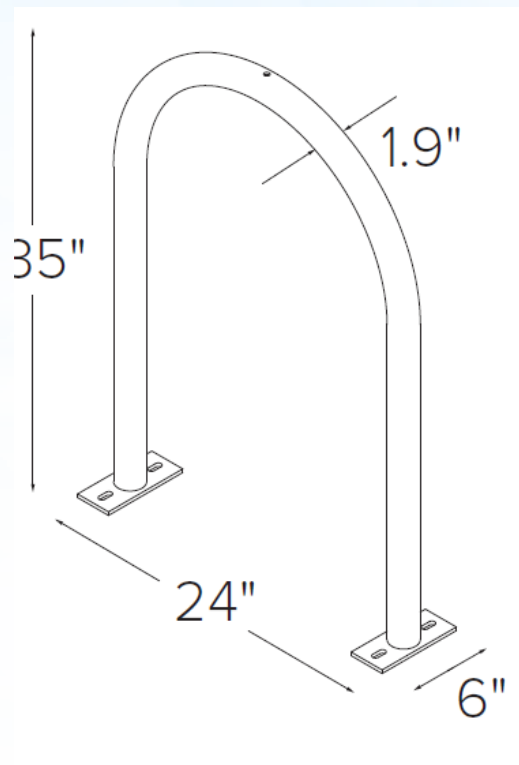



# FHT Safety Initiative



**HAVERFORD**

**WALKS &  
BIKES**



- FHT bike bell giveaway to “deconflict” bike/ped interaction on trails
- Offering Bike Safety classes to School District - awaiting action